

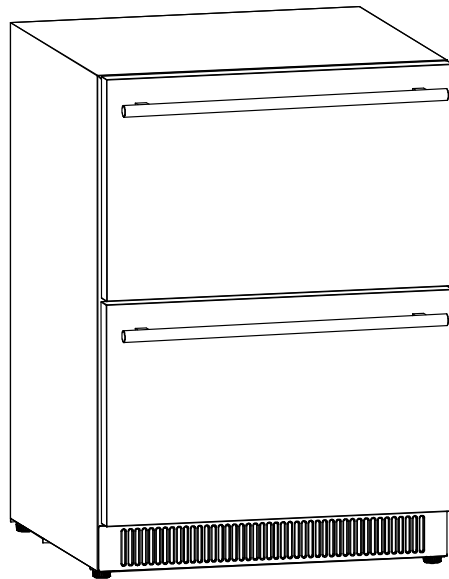

BLAZE™

OUTDOOR KITCHEN + GRILLS



USER GUIDE

Blaze 24-Inch 5.6 Cu. Ft. Outdoor Rated Stainless Steel Double Drawer Refrigerator

BLZ-SSRF-DBDR5.1



SCAN TO REGISTER

[BlazeGrills.com](https://www.BlazeGrills.com)

Table of Contents:

Unpacking Your Unit	2
Blaze Introduction and Records	3
General Safety and Installation Warnings	4
Important Safety Instructions	5
Appliance Specifications	6
Exploded View	7
Dimensions and Capacity	8
Wiring Diagram and Control Panel	9
Operating Your Cooler	10-11
Location and Installing Your Appliance	12
Controlling Humidity	13
Winter Storage	14
After Winter Storage	15
Installation of Your Appliance	16-18
Care and Maintenance	19
Troubleshooting Guide	20
Warranty	21
Frequently Asked Questions:	22

Unpacking Unit:

Your Blaze Appliance comes preassembled and requires very little setup.

⚠️ Product Inspection: A final inspection of your product occurs at the factory to ensure a quality product is packaged. Please re-check for possible shipping damage immediately after unpacking your appliance. If the appliance is found to have some damage, contact your dealer immediately as often the shipping carrier will have a time frame to report damage. Remove all packaging materials, labels and protective plastic film before you using your appliance and please save the packaging material if there is shipping damage. Keep all packaging and document condition of appliance upon arrival.

⚠️ Caution: Do not leave the unit under the sun with the protective film as it will make the film difficult to remove and/or leave markings on the materials which are not covered by the warranty.

⚠️ Before Using Your Unit: Clean the interior surface with lukewarm water using a soft cloth. Check to be sure you have all of the following parts:

- 1 Instruction Manual
- Handle
- Decoration Cover For Handle
- Keys
- Anti-toppling support
- Anti-toppling support Screws
- Double-sided tap





A Special Message to Our Customers:

Congratulations on your purchase of a Blaze product! At Blaze, we pride ourselves on creating high-quality, durable, and innovative outdoor solutions that inspire memorable experiences and exceed expectations. Our passion for craftsmanship, performance, and outdoor living drives everything we do.

This manual provides easy-to-follow instructions for installing, operating, and maintaining your Blaze appliance. We recommend reading this manual carefully before your first use to ensure safety, proper care, and optimal performance. Your appliance is designed and built with meticulous attention to detail, using premium materials and cutting-edge manufacturing processes, so you can enjoy years of reliable, efficient, and satisfying use.

We are committed to providing exceptional products and unparalleled customer service. Your satisfaction is our top priority, and we stand behind the quality and workmanship of every Blaze product.

Thank you for choosing Blaze and welcome to our family of passionate outdoor enthusiasts. We look forward to being a part of your outdoor adventures and helping you create cherished memories with family and friends.

Sincerely,

Blaze



5 year limited warranty, see pg 21 for details.

Lifetime limited warranty for complete warranty information, product must be registered to validate the warranty. Terms apply.



Please Retain for Your Records:

For your convenience, please record the following information, which can be found on the data name plate located on the back top of the fridge, a second label with the model number and serial number is located on the box. Please refer to this information when contacting Blaze or an authorized service agent.

MODEL #:

SERIAL #:

DATE OF PURCHASE:

PLACE OF PURCHASE:

120 Volt/ 1.5 AMP

To the Installer:

Please read these instructions carefully before installation and give this manual to the owner.

To the Owner:

Keep this manual in a safe place for future reference



General Safety and Installation Warnings

WARNING



READ INSTRUCTIONS: Please read this manual carefully and before using your BLAZE Appliance to ensure proper operation, installation, servicing and to reduce the risk of fire, burn hazard and or other injury. Improper installation and service or maintenance may cause property damage, injury or death. Keep this manual handy and do not operate without reading this manual.



GROUNDING HAZARD: Plug into a grounded 3-prong outlet, do not remove grounding prong, do not use an adapter, and do not use an extension cord. If the SUPPLY CORD is damaged, it must be replaced by the manufacturer, its service agent or similarly qualified persons in order to avoid a hazard.



EXPLOSION HAZARD: Never clean refrigerator parts with flammable fluids. These fumes can create a fire hazard or explosion. And do not store or use gasoline or other flammable vapors and liquids in the vicinity of this or any other appliance. The fumes can create a fire hazard or explosion.



RECEPTACLE HAZARD: Only It is recommended that a separate circuit, serving only your refrigerator be provided. Use receptacles that cannot be turned off by a switch or pull chain.



WEATHER PROTECTION: Positioning and Shelter: While outdoor refrigerators are designed to handle the elements, placing the fridge under a covered area like a pergola or in an outdoor kitchen structure can help shield it from direct sunlight, rain, and snow, which extends the appliance's life. Temperature Extremes: Outdoor fridges are built to handle fluctuations in weather, but extreme conditions e.g., below-freezing temps) may affect performance. Some fridges have heaters to handle colder weather, but others may not operate well if the temperature drops too low.



IN MASSACHUSETTS: Make sure the installation complies with Massachusetts state building and electrical codes. Outdoor electrical outlets, especially those exposed to moisture, must be GFCI (Ground Fault Circuit Interrupter) protected. A licensed electrician should install the outlet for safety and code compliance. Depending on where you live in Massachusetts, you may need permits to install certain outdoor appliances. Always check with your local building department for any necessary permits and inspections.



HANDLE WITH CARE: It is generally recommended to keep a refrigerator upright for at least 24 hours before plugging it in, especially if it has been transported or tilted during delivery. This allows the refrigerant oil, which may have moved during transport, to settle back into the compressor where it belongs.



RISK OF ELECTRIC SHOCK: Do not connect or disconnect the electric plug when your hands are wet. Unplug the refrigerator or disconnect power before cleaning or servicing. Failure to do so can result in electrical shock or death.



RISK OF CHILD ENTRAPMENT: Before you throw away your old refrigerator or freezer:
* Take off the doors.
* Leave the shelves in place so that children may not easily climb inside.



CALIFORNIA PROPOSITION 65 WARNING: This product can expose you to chemicals including chromium (hexavalent compound), which is [are] known to the State of California to cause cancer [and] [or] [birth defects or other reproductive harm. For more information go to www.p65warnings.ca.gov



Important Safety Instructions

General

- **Follow local codes:** The appliance should be installed in accordance with local electrical code requirements. It should also be placed in a location that is strong enough to support its total weight, keeping in mind that it will weigh substantially more when fully loaded than when empty.
- Do not attempt to repair or replace any part of your refrigerator unless it is specifically recommended in this manual. All other servicing should be referred to a qualified technician. Consult repair manual or owner's guide before attempting to service this product. All safety precautions must be followed.
- Before you plug the appliance into a power supply, be sure to let it stand upright for at least 24 hours to allow the compressor's oils to settle.
- Use two or more people to move and install refrigerator. Failure to do so can result in back or other injury.
- The refrigerator must be installed with all electrical, water and drain connections in accordance with state and local codes. A standard electrical supply (115 V AC only, 60 Hz), properly grounded in accordance with the National Electrical Code and local codes and ordinances is required.
- Do not kink or pinch the power supply cord of refrigerator.
- The fuse (or circuit breaker) size should be 15 amps.
- It is important for the refrigerator to be leveled in order to work properly. You may need to make several adjustments to level it.
- All installation must be in accordance with local plumbing code requirements.
- Make certain that the lines are not pinched, kinked or damaged during installations.
- Check for leaks after connection.
- Never allow children to operate, play with or crawl inside the refrigerator.
- Do not use solvent-based cleaning agents or abrasives on the interior. These cleaners may damage or discolor the interior.
- Do not use this apparatus for other than its intended purpose.

- To ensure proper ventilation for your refrigerator, the front of the unit must be completely unobstructed. Choose a well-ventilated area with temperatures above 60°F (16°C) and below 90°F (32°C). This unit must be installed in an area protected from the element, such as wind, rain, water spray or drips.
- To prevent injuries, do not use accessories that are not recommended by the manufacturer.
- Before cleaning the appliance, disconnect power cord.
- Do not store items of interest to children in cabinets above the appliance or in the appliance. Children climbing on the appliance to reach these items could be seriously injured.

Severe Weather

- **Storm and wind resistance:** Some states are prone to nor'easters and coastal storms, particularly in coastal areas. Consider securing your fridge with proper anchoring or bracing if it's free-standing to prevent it from tipping during high winds. Placing the fridge in a sheltered area like a covered patio or outdoor kitchen can also provide some protection from severe weather.

Coastal considerations (if applicable)

- **Corrosion risks:** If you're near the coast, salty air can lead to corrosion on metal parts. Choose an outdoor fridge made from 304 or 316 stainless steel, which are more resistant to corrosion. Even with corrosion-resistant materials, regular cleaning and maintenance are essential to prevent rust from developing.



Warning; risk of fire/flammable materials

WARNING: When positioning the appliance, ensure the supply cord is not trapped or damaged.

WARNING: Do not locate multiple portable socket-outlets or portable power supplies at the rear of the appliance.

Specifications and Dimensions

Specifications:

Installation	Built-in or Free standing
Net volume capacity - Ture (L/cu.ft)	158L
Rack Type	304 stainless steel
Bottle loading capacity (355ml cans)	154 cans
Temperature range refrigerator (°C/°F) high/ low	1-20°C (34-68°F)
Thermostat	White LED
Temperature memory setting	Yes
Alarm Type (Temp alarm and door ajar alarm)	Yes
Material	304 stainless steel exterior cabinet and Black aluminum sheet

Interior light	White LED
Leveling legs	4
Refrigerant	R600a
Power input @ 115V	115V / 1.5A
Safety certification agency	CSA (US) household outdoor rated
Energy effeciency verification agency	CSA
Energy consumption/ category/Energy Star	Refrigerator, Department of Energy, EnergyStar
Power cord length	6 feet / 72 inch
Width	605mm / 23 7/8"
Height	867mm / 34 1/8"
Depth	602mm / 23 3/4"



Exploded View

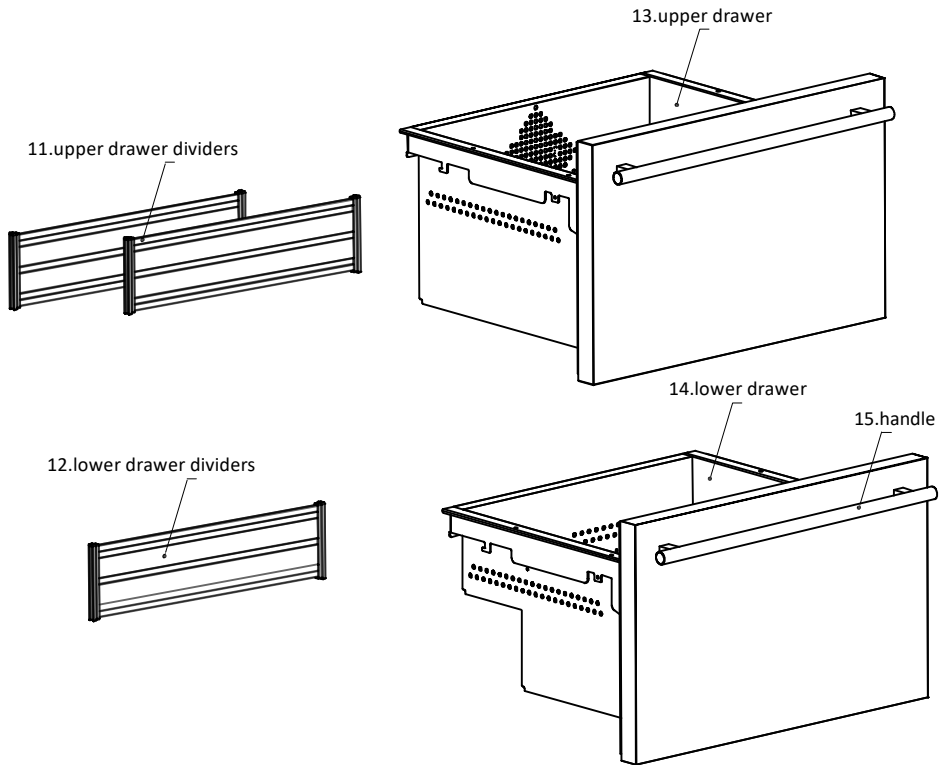
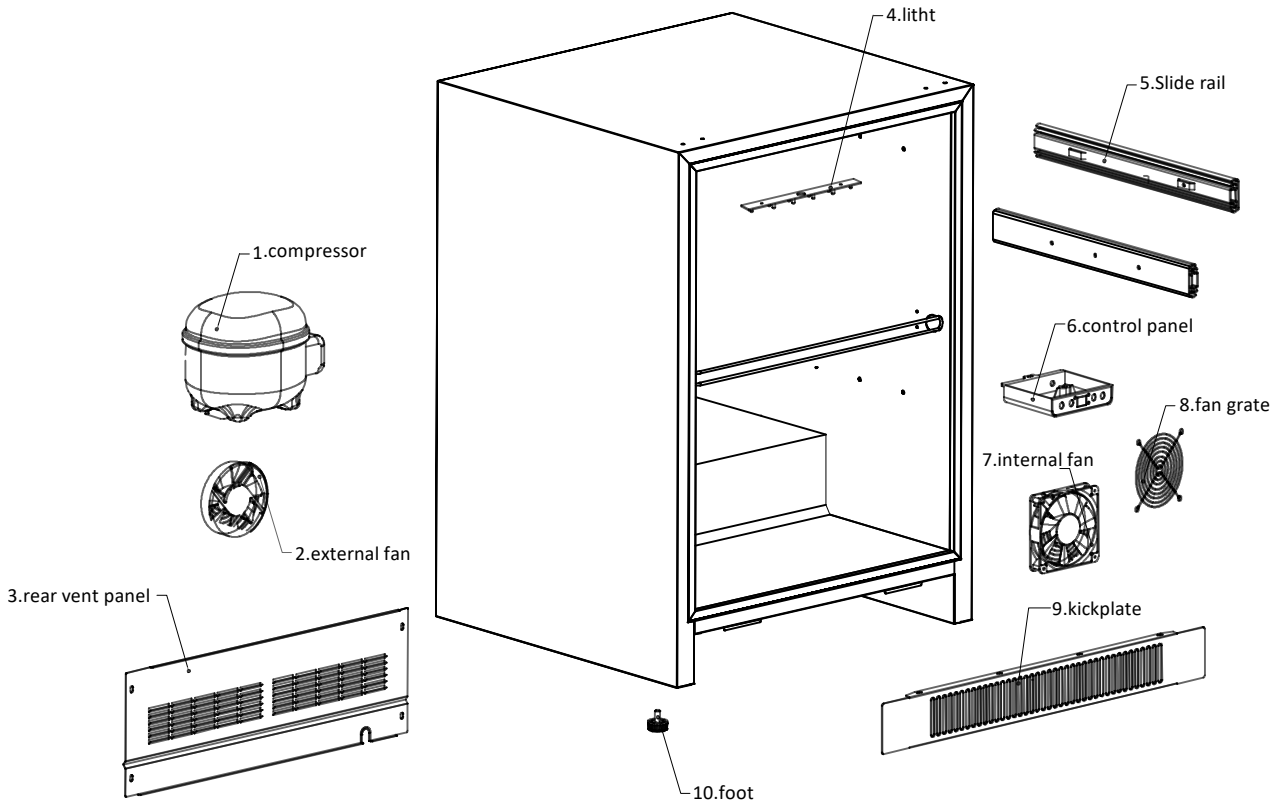

Dimensions and Capacity

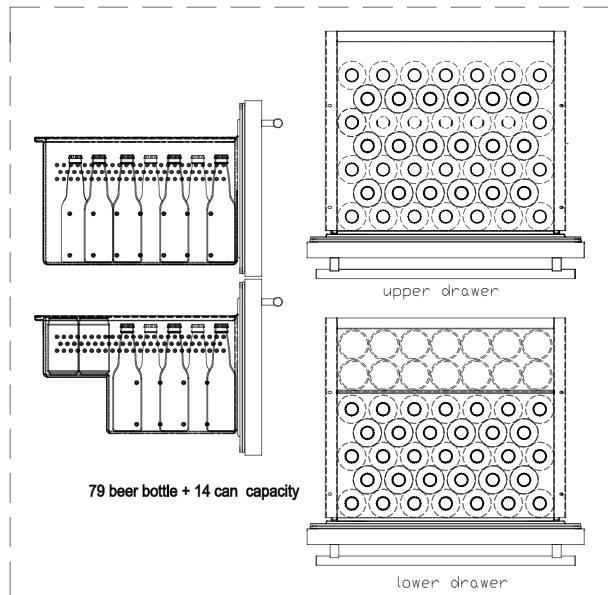
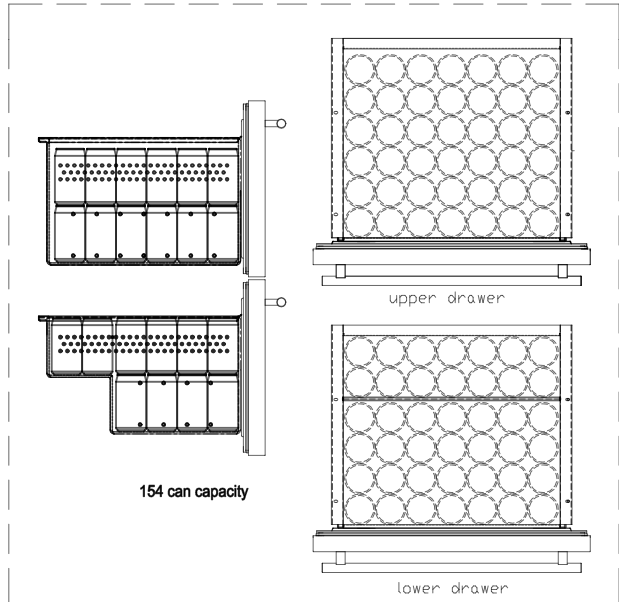
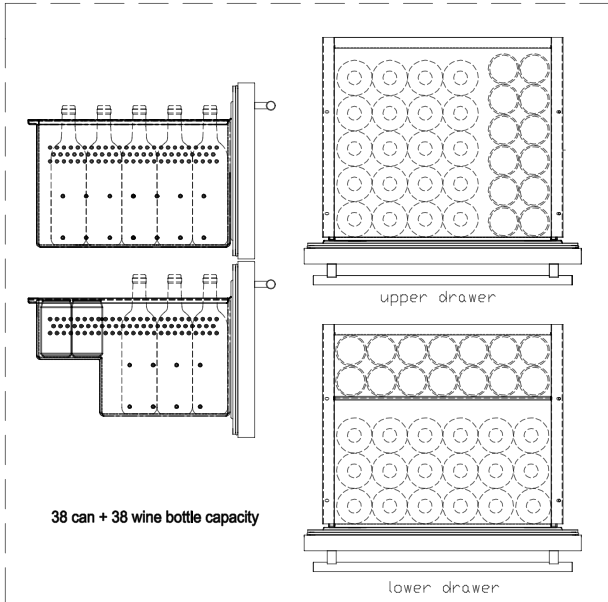
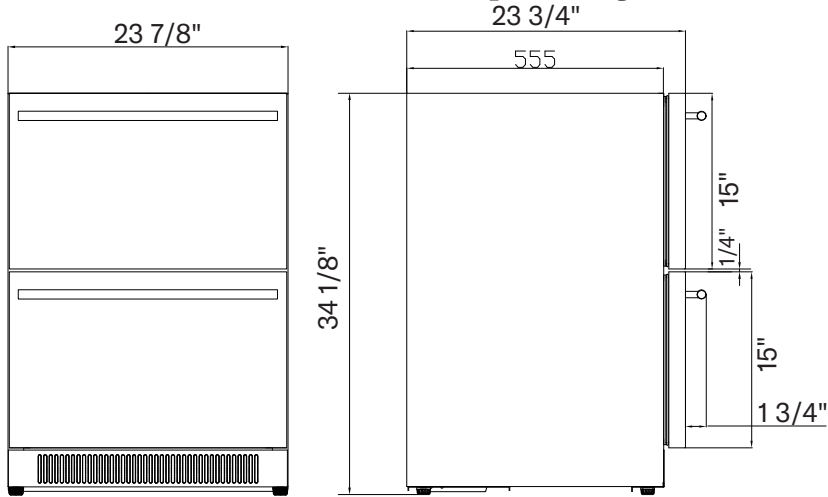



Wiring Diagram

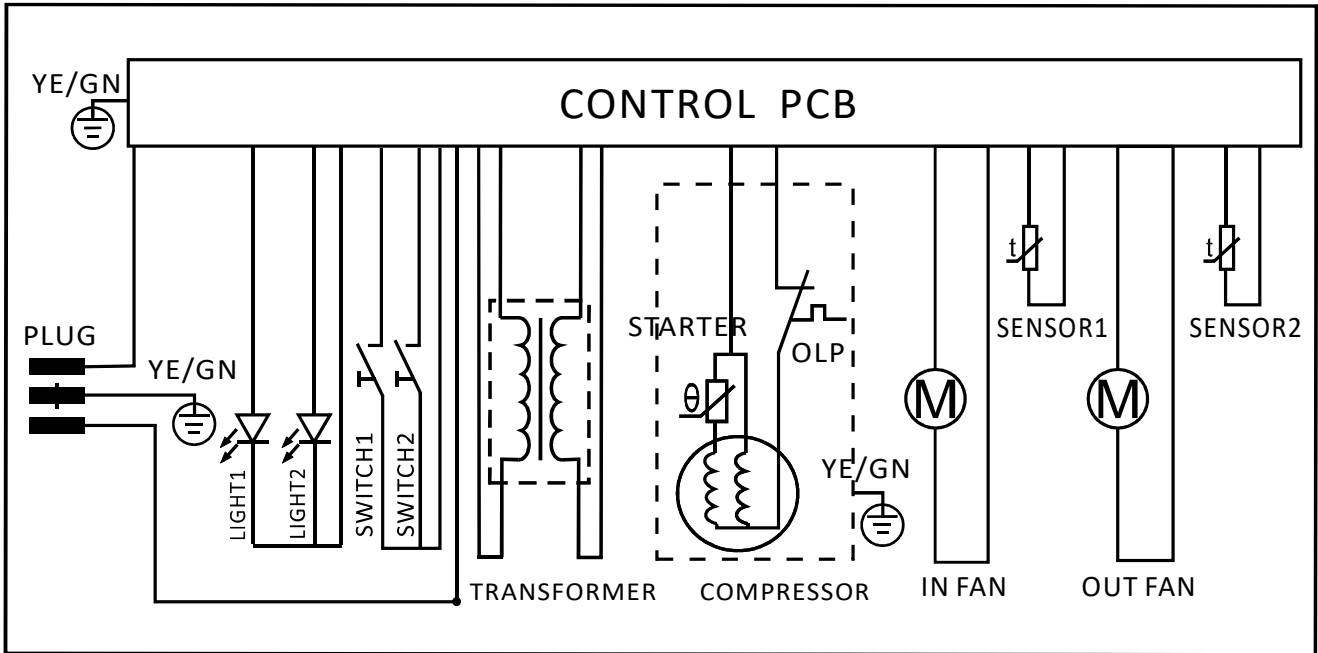

Control Panel

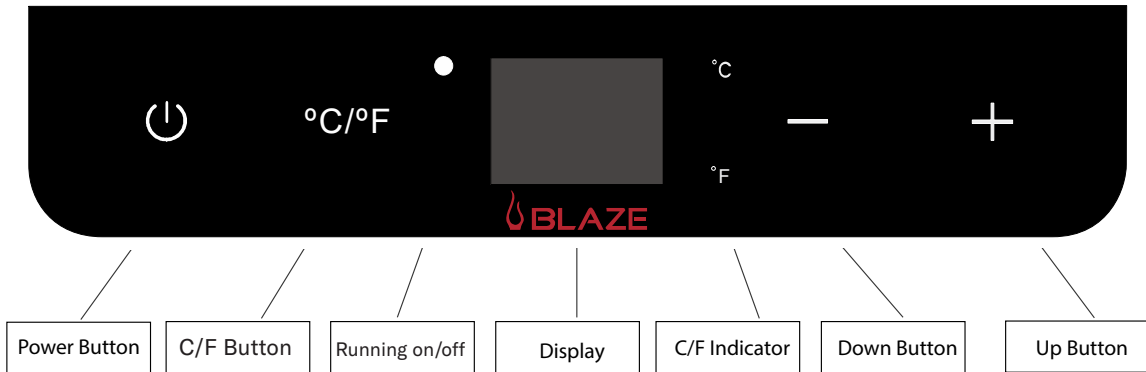

OPERATING YOUR APPLIANCE

It is recommended that you install the appliance in a place where the ambient temperature is between 50°F and 109.4°F (10°C-43°C). If the ambient temperature is above or below recommended temperatures, the performance of the unit may be affected. For example, placing your unit in extremely cold or hot conditions may cause interior temperatures to fluctuate. The operating temperature range may not be reached.

CONTROL PANEL

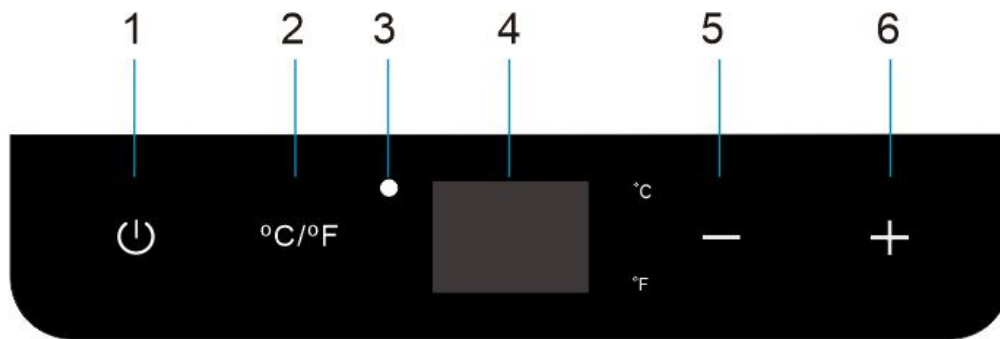

The temperature setting can be adjusted from 34°F to 68°F (or 1°C to 20°C) .

1. To turn the unit ON and OFF, press and hold this button for approximately 3 seconds.
2. Press this button to toggle between controls in degrees Fahrenheit or degrees Celsius.
3. Indicates that compressor is operating.
4. Shows the set temperature of the cabinet.
5. Press this button to decrease the temperature by one (1) degree increments.
6. Press this button to increase the temperature by one (1) degree increments.

Sabbath Mode

Sabbath mode disables system responses to user-initiated activities and all external functions, including lighting, display and audible alarms. The unit will still maintain internal temperatures and set points. To enable or disable Sabbath mode Press the power button ,At the same time.Press up button twice. The interior light and control display will go dark until the user disables Sabbath mode.

Temperature Alarm

If the interior temperature is higher than 77°F (25°C), “HI” is shown on the temperature control panel and the temperature alarm will sound continuously after one hour. This indicates that the inner temperature is too high. If the inner temperature is lower than 25°F (-4°C), “LO” is shown on the temperature display panel and the temperature alarm will sound continuously after 15 minutes. If one of these situations occur, please reference the troubleshooting section for support.



Door Ajar Alarm

Your unit is equipped with an audible alarm to alert you when the door has been left open.

If at any time the door has been left open for more than 3 minutes at a time, the alarm will sound and then will continue to sound until the door is closed completely or the unit is powered off.

Temperature Memory Function

If the power is suddenly lost, the set temperature will be saved by the unit. Once the power is back on, the unit will be at the same set temperature.

Defrosting

The unit is designed with an automatic defrost system. However, on colder settings, some frost may build up. Additionally, the more humid the ambient conditions, the more frost may build up. Keep the door closed as much as possible and avoid opening the door unnecessarily to minimize frost build-up.

If frost is preventing the door from closing properly, you may need to power the unit off until the frost melts (possibly up to 24 hours). Use a soft absorbent towel to dry the unit.

Location and Installing Your appliance

Installing and setting up your Blaze 20-Inch Refrigerator is crucial for optimal performance and longevity. Here's a comprehensive guide to ensure proper installation, especially in outdoor or varying environments.

Step 1. Unpacking and Initial Preparation

Remove all packaging: Carefully unbox the refrigerator, removing all interior and exterior packaging materials. **Clean the Unit:** Wipe the exterior with a soft, dry cloth and the interior with a lukewarm wet cloth. **Check Included Parts:** Ensure you have 3 shelves, instruction manual, decoration cover for lock, decoration cap for lock, keys, left hinge, left hinge screws, and decoration cap for hinge.

Step 2. Choosing the Right Location

Stable Surface: Place the refrigerator on a floor strong enough to support it when fully loaded. **Avoid Direct Sunlight and Heat:** Keep away from direct sunlight and heat sources like stoves or radiators to prevent increased electrical consumption. **Consider Ambient Temperature:** Avoid extremely cold environments as they may cause the appliance to perform improperly. **Moisture Considerations:** Don't use near water sources like in wet basements or near sinks.

Step 3. Proper Ventilation and Clearance

Freestanding design: The appliance is designed to be freestanding or Built-in Requirements.

Back ventilation: Ensure proper ventilation at the back for compressor and condenser cooling.

Step 4. Pre-Power Setup

Upright settling: Let the appliance stand upright for approximately 24 hours before connecting to power to allow compressor oils to settle. **Leveling:** Adjust the four leveling legs at the bottom to ensure the unit is perfectly level.

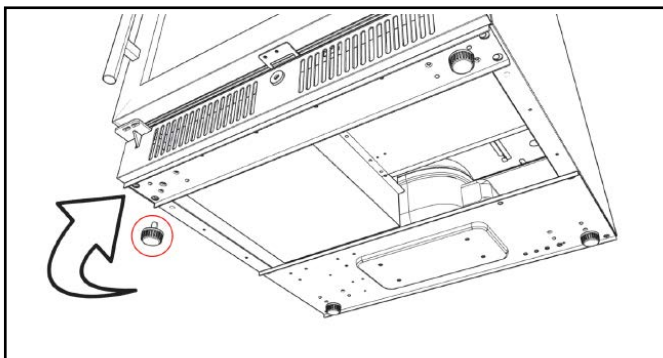

BlazeGrills.com

Step 5. Electrical Connections

Proper outlet: Use a standard 115 Volt AC /60Hz electrical outlet with three-prong ground. **Grounding Importance:** Never remove or alter the third (ground) prong from the power cord. **Dedicated Circuit:** Use a dedicated circuit matching the appliance's voltage rating. **Cord Management:** Secure the cord behind the unit to prevent accidental injury or disconnection.

Step 6. Powering On and Initial Cooling

First power-up: After plugging in, allow the unit to cool for 2-3 hours before placing contents inside. **Temperature Setting:** Adjust the temperature control to your desired setting (details not provided in original text).

Step 7. Safety and Compliance

Local codes: Install in accordance with local electrical code requirements. **Professional consultation:** Consult a certified electrician for any power or grounding questions. **Outlet Replacement:** If you have a 2-prong outlet, have it replaced with a grounded 3-prong outlet by a qualified electrician.

Step 8. Maintenance and Care

Regular inspections: Periodically check the power cord for damage and replace if frayed or damaged. **Cleaning:** Regularly clean the interior and exterior. **Door Seal:** Check and maintain the door seal to ensure proper closure and efficiency.



Controlling Humidity

Humidity is only sometimes an issue, depending on the location of the appliance. If so, these methods can help control or mitigate humidity.

Controlling humidity in an outdoor refrigerator is important to ensure optimal performance, prevent mold and mildew, and keep your food and beverages in good condition. Here's how to manage humidity effectively, especially in areas with fluctuating weather conditions.

1. Use a Dehumidifier Pack

Silica gel packs: Place silica gel or other moisture-absorbing packs inside the fridge to help control moisture levels. These packs can absorb excess humidity and prevent condensation from building up inside the fridge.

Rechargeable dehumidifiers: There are small, rechargeable dehumidifiers designed for use in appliances like fridges. These can help reduce humidity and protect against mold and mildew.

2. Maintain Proper Ventilation

Ensure proper airflow: Outdoor fridges should have proper ventilation to prevent humidity from building up. Make sure the vents on the back or sides of the fridge are clear of obstructions. In areas with high humidity, it's even more important to have sufficient airflow to prevent moisture buildup.

Avoid overpacking: Don't overfill the fridge, as crowded items can reduce airflow, causing humidity to rise and condensation to form inside.

3. Keep the Door Sealed

Check the door seal: Make sure the refrigerator door is closing properly and the seal is intact. If the seal is damaged, replace it. A faulty seal can let warm, moist air in, increasing humidity levels inside the fridge.

Limit door opening: Try to minimize how often and how long you open the fridge door, especially during humid days. Warm, humid air enters the fridge each time the door is opened, causing condensation to form.

4. Monitor the Temperature and Humidity

Use a thermometer and hygrometer: Consider placing a small digital thermometer and hygrometer (to measure humidity) inside the fridge. This will help you keep track of both temperature and humidity levels and adjust as necessary.

Ideal humidity levels: Aim for a relative humidity level inside the fridge of around 30-50%. If it goes higher, you may experience moisture buildup, while too low a humidity level can dry out food.

5. Adjust Temperature Settings

Colder temperatures reduce humidity: If you notice excessive humidity inside the fridge, try lowering the temperature slightly. Colder air can hold less moisture, so reducing the temperature can help reduce condensation.

Avoid freezing: Be careful not to lower the temperature too much, especially if the outdoor temperature is already cold, as this can cause food to freeze.

6. Wipe Down Condensation Regularly

Check for moisture buildup: During humid days or seasonal changes, check the fridge for signs of condensation on the shelves, walls, and food containers. Wipe down any moisture with a clean, dry cloth to prevent mold growth.

Dry the interior after cleaning: Whenever you clean or wipe down the fridge, make sure it's completely dry before closing the door.

7. Sheltered Placement

Keep It under cover: While outdoor fridges are built to withstand the elements, placing the fridge in a more sheltered area (like under a pergola or in a covered outdoor kitchen) can reduce direct exposure to humidity. This will help minimize the fridge's interaction with humid air. By following these steps, you'll be able to manage humidity in your outdoor fridge, keeping it in top working condition and preventing moisture-related issues.

Winter Storage

If you plan to store your outdoor refrigerator for the winter (rather than leaving it in place), follow these steps to ensure it's properly protected and ready to use when warmer weather returns:

Step 1. Unplug and Power Down

Turn Off the Power: Unplug the refrigerator from the electrical outlet. If the fridge is hardwired, turn off the circuit breaker. This prevents any accidental power surges or running the appliance during cold weather.

Step 2. Empty and Clean the Fridge

Remove All Contents: Take out all food, beverages, and removable shelves or drawers.

Clean the Interior: Wipe down the interior surfaces with a mild cleaning solution or a mix of baking soda and water. Pay extra attention to corners and crevices to avoid leaving behind any crumbs or spills that could cause odors or attract pests.

Dry thoroughly: Make sure the fridge is completely dry before storing. Any remaining moisture can lead to mold or mildew growth during storage.

Step 3. Clean the Exterior

Wipe down the outside: Clean the exterior with a damp cloth, and if needed, use a mild detergent to remove grime or salt (especially if you're near the coast). Make sure the fridge is dry before storing.

Check for rust or corrosion: Inspect any metal parts for rust or corrosion. If you spot any, clean and apply a rust inhibitor or polish to prevent further damage.

Step 4. Leave the Door Ajar

Prevent odors and mold: Prop the refrigerator door slightly open during storage to allow airflow inside. This prevents mold, mildew, and odors from building up. Use a towel or a door wedge to keep the door ajar.

Step 5. Remove and Store Shelves

Protect removable parts: Remove shelves, trays and store them separately. Wrapping these in protective material (like bubble wrap) will prevent them from getting damaged during the move or storage.

Step 6. Choose a Dry, Safe Storage Location

Indoor storage preferred: If possible, store the fridge in a dry, temperature-controlled environment like a garage, basement, or shed. If you're storing it outside, choose a well-sheltered area (e.g., under a covered patio.)

Avoid freezing temps: Prolonged exposure to freezing temperatures can damage the internal components of the fridge. If you're storing it in an unheated space, consider using a fridge cover with insulation.

Step 7. Prepare for Moving

Secure and protect: If moving the fridge to storage, secure the door with tape or a bungee cord. Use padding or blankets to protect the fridge from damage.

Use a Dolly: Refrigerators are heavy and cumbersome to move, so use a dolly or a hand truck to transport it safely. Always keep the fridge upright during the move to prevent refrigerant from shifting within the unit, which can cause compressor damage.

Step 8. Check Before Reusing in Spring

Inspect the Unit: Before you plug the fridge back in after winter storage, inspect the interior and exterior for any signs of damage, mold, or pests. Clean the fridge again and let it run for a few hours to ensure it's working. If the fridge has been laid down, make sure you stand it upright for 24 hours.



After Winter Storage

When spring arrives, it's time to prepare your outdoor fridge for use again. Here's how to ensure it functions well after winter storage:

Step 1: Inspect for Any Winter Damage

Check the exterior: Look for signs of rust, corrosion, or weather damage on the fridge's surface. If you used a cover, remove it and inspect any seals or vents for debris or moisture that may have accumulated.

Inspect electrical connections: If the fridge was unplugged or the circuit was turned off, ensure that the outlet, plug, and any other electrical connections are free of moisture or damage. Make sure the GFCI outlet is functioning correctly by pressing the test and reset buttons.

Step 2: Clean the Interior Again

Wipe down all surfaces: Even though you cleaned it before winter, a light cleaning will help remove any dust, debris, or odors that might have developed. Use a mild cleaning solution or a baking soda-water mixture.

Check for mold or mildew: Inspect corners and hard-to-reach areas for any mold or mildew growth. If you spot any, use a vinegar-water solution to clean the surfaces thoroughly.

Step 3: Reattach or Reconnect the Water Line (if applicable)

Reconnect the water line: If your fridge has an ice maker or water dispenser, reconnect the water line if it was disconnected during winterization. Make sure it's securely attached and check for any leaks.

Flush the Line: After reconnecting, let water flow through the line for a few minutes to flush out any debris or buildup that may have accumulated during the winter.

Step 4: Test the Power

Plug in the fridge: Reconnect the fridge to the electrical outlet or turn the circuit back on if it was hardwired. Before loading the fridge, give it time to reach the proper temperature (usually a few hours).

Check for Power Issues: Once powered on, ensure the compressor is running smoothly, and there are no unusual

noises. Test any lights or fans to make sure they are functioning correctly.

Step 5: Check Door Seals and Hinges

Test the Door Seal: Ensure that the fridge's door seal is still tight and forms a good seal when closed. This helps the fridge maintain its cooling efficiency. If the seal is worn, replace it to avoid cooling issues.

Lubricate Hinges (if needed): If the door hinges feel stiff or make noise, apply a food-safe lubricant to the hinges to ensure they operate smoothly.

Step 6: Restock the Fridge Slowly

Allow Time for Cooling: Before filling the fridge with food and beverages, give it time to reach the proper operating temperature. Restocking the fridge while it's still warming up may cause it to work harder and reduce its efficiency.

Monitor the Temperature: Use a thermometer to confirm that the fridge is cooling to the desired temperature, usually around 37-40°F (3-4°C).

Step 7: Check and Clean the Condenser Coils

Clean the Coils: The condenser coils (usually located at the back or bottom of the fridge) can collect dust and debris over time. Use a brush or vacuum to clean the coils, which will help the fridge run more efficiently and extend its lifespan.

Ensure Proper Ventilation: Make sure the area around the fridge is clear to allow proper air circulation, especially around the vents and coils. This helps maintain optimal cooling performance.

Step 8: Monitor Performance for the First Week

Keep an Eye on the Unit: In the first few days of operation, check the fridge regularly to ensure it's cooling properly, there are no leaks, and it's functioning as expected. Listen for any unusual sounds or issues with the compressor.

By following these steps, your outdoor refrigerator will be in top condition and ready for use in the warmer months.

Installation of your appliance

Your outdoor drawers' refrigerator has been designed for both built-in and free standing.

For best performance, do not install the appliance behind a cabinet door or block the base grille.

Avoid locating the unit in moist areas.

Plug the appliance into an exclusive, properly grounded wall outlet.

1. Position the unit to allow free air flow through the front grille.

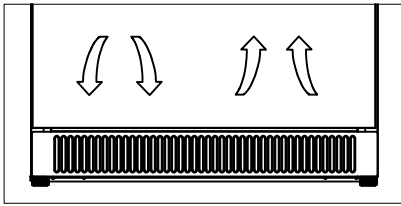

2. Wipe out inside of unit with a damp cloth.
3. Be sure to install the Anti-Tip bracket. Follow the instructions provided with the Anti-Tip bracket kit.



The Anti-Tip Kit must be installed on this unit before it is used. Double stacking units may cause serious personal injury.

ANTI-TIP BRACKET INSTALLATION

To reduce the risk of tipping the unit by abnormal usage or improper loading secured by properly installing the anti-tip device packed.

Freestanding Against a Wall:

1. Attach the left and right anti-tip brackets onto the refrigerator drawers with 3M tape.
2. Secure the left and right anti-tip brackets with (3) screws each to the back wall at the back of the refrigerator.

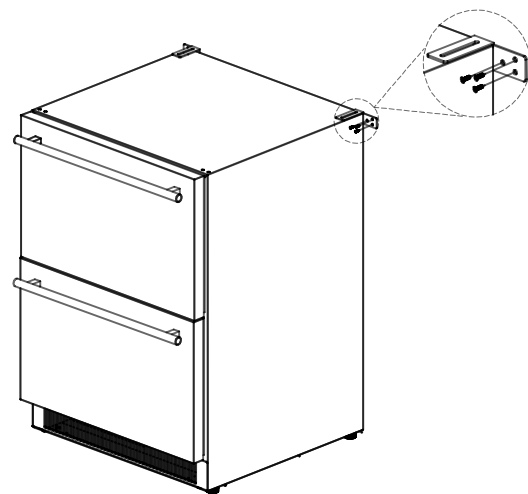
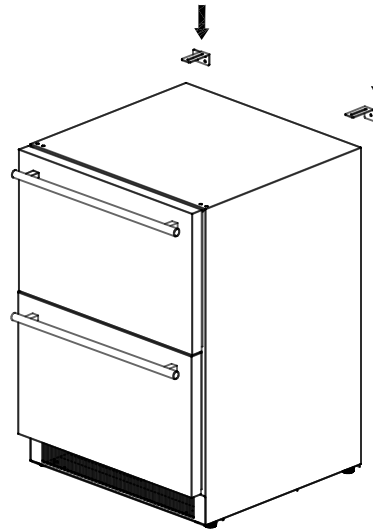



Underneath a Countertop:

step 1: Fixed the left anti-trip bracket(3) and right anti-trip bracket (4) on the top of both side of appliance by two screws (5)

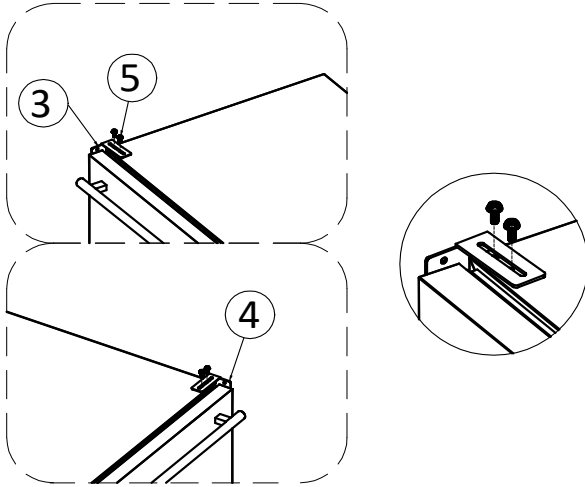

step 2: Slide the appliance into the position inside cupboard as shown in the figure

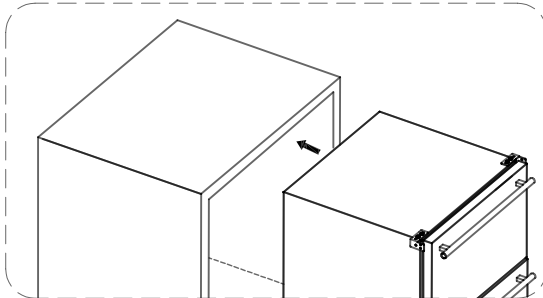

step 3: Secure the left and right anti-trip bracket into the cupboard by two screws (2).

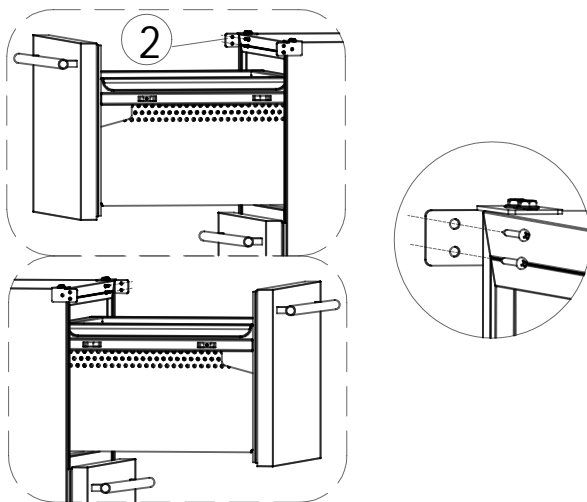

Noted: If the unit is relocated, the bracket must be removed and installed in the new location.

Remove the upper drawer

1. Slide the upper drawer out
2. Loosen four screws as shown in figure 3. Lift the drawer lightly and take it out.

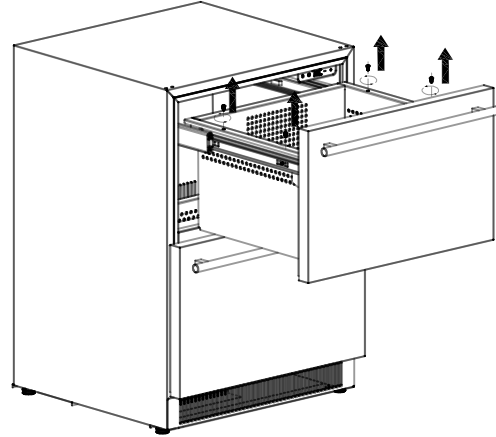

Remove the lower drawer

1. Make sure the upper drawer is removed and the drawer door slide out as shown in figure
2. Slide the lower drawer out and loosen four screws.
3. Lift the lower drawer lightly and take out the drawer from left or right side as shown in figure.

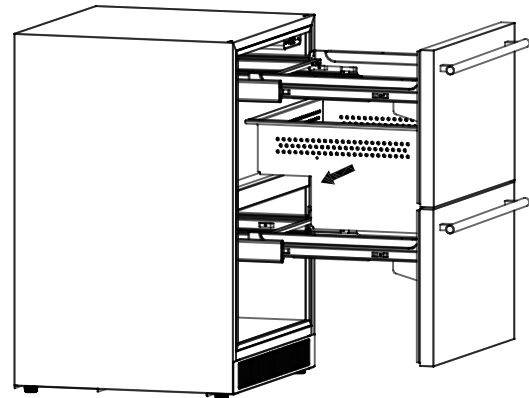
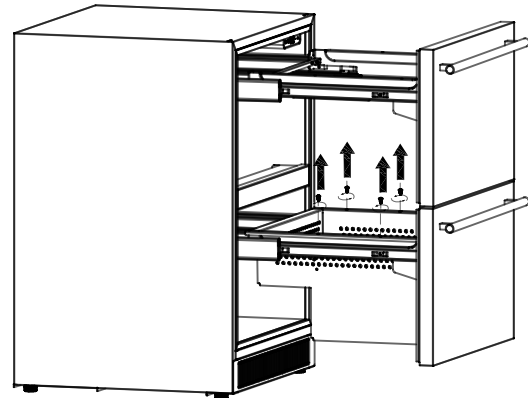

Noted: If you want to re-installing the drawer. just simply place the drawer back and align the four holes. Then tighten the screws.

Installing the Door Handle

1. Sliding out the drawer. There are two handle hole on top of both side of the drawer panel.
2. The plastic pad, flat washers, spring washers, screws has been pre-installed on door panel.
3. Align the screw with handle hole and install it.
4. Take out the decorative cover from accessories bag. Then install it to the handle hole.

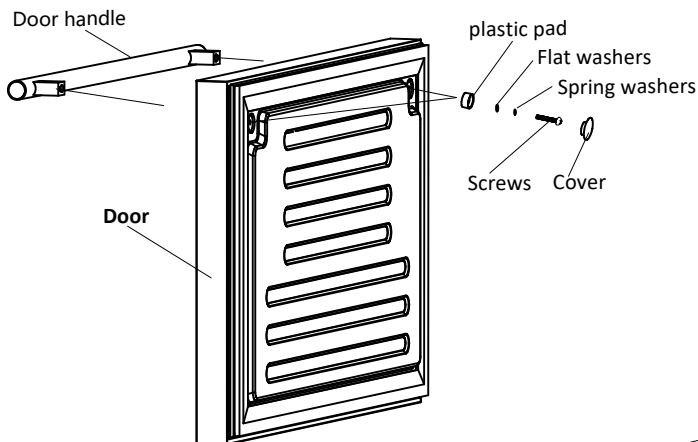

BUILT-IN INSTALLATION

ATTENTION:

This unit has been designed for freestanding or built-under installation. In every case, there must be adequate ventilation and access for service.

FREESTANDING INSTALLATION:

Freestanding installation will allow you to install the unit in almost any indoor/outdoor place you desired. You must follow the stated instructions for electrical requirements, recommended install area and leveling of this unit.

BUILT-UNDER INSTALLATION

When installing this unit under a counter, follow the recommended spacing dimensions shown. Always keep any ventilation openings clear of obstruction.

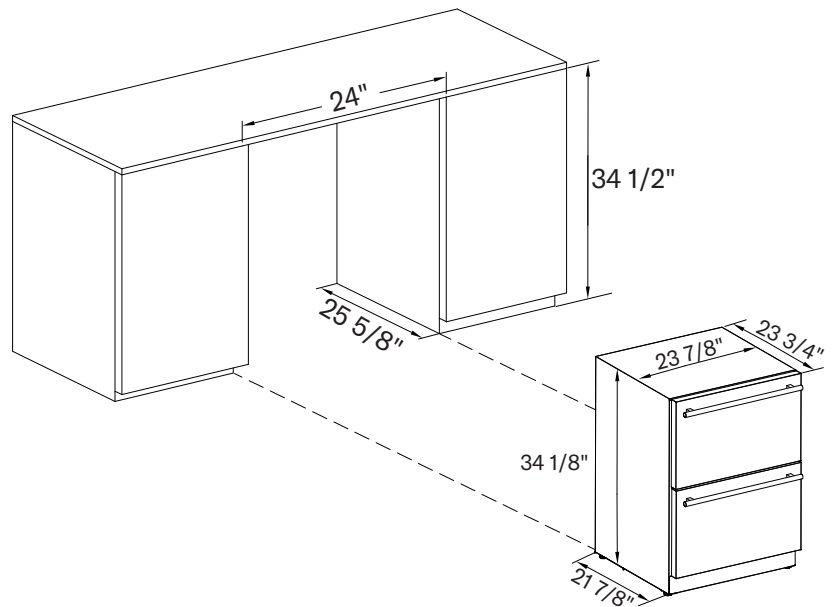



Care and Maintenance

Do not use boiling water to melt any frost, because it may damage the plastic parts. In addition, never use a sharp or metallic instrument to remove frost as it may damage the cooling system and will void the warranty. We recommend using a plastic scraper. To removed any ice if necessary.

(A) Cleaning Your Unit:

Turn off the fridge, unplug the unit, and remove the contents, shelf, and tray.

Wash the inside surfaces with a warm water and baking soda solution. The solution should be about 2 tablespoons of baking soda to a quart of water.

Wash the shelf and tray with a mild detergent solution.

The outside of the unit should be cleaned with mild detergent and warm water.

Squeeze excess water out of the sponge or cloth before cleaning the area of the controls, or any electrical parts.

Wash the outside cabinet with warm water and mild liquid detergent. Rinse well and wipe dry with a clean soft cloth.

(B) Power Failure:

Most power failures are corrected within a few hours and should not affect the temperature of your unit if you minimize the number of times the door is opened. If the power is going to be off for a longer period of time, you need to take the proper steps to protect your contents.

(C) Vacation Time:

Short vacations: Leave the unit operating during vacations of less than three weeks.

Long vacations: If the appliance will not be used for several months, remove all content and unplug the power cord. Clean and dry the interior thoroughly. To prevent odor and mold growth, leave the door open slightly: blocking it open if necessary.

(D) Moving Your Unit:

- Remove all contents.
- Securely tape down all loose items inside your unit.
- Turn the leveling legs up to the base to avoid damage.
- Tape or a bungee cord the door shut.
- Be sure the unit stays secure in the upright position during transportation. Also protect the outside of unit with a blanket, or similar item.

(E) Energy Saving Tips:

- The unit should be located in the coolest area of the room, away from heat producing appliances, and out of the direct sunlight.
- Let hot items cool to room temperature before placing in the unit. Overloading the unit forces the compressor to run longer.
- Wipe containers dry before placing them in the unit. This cuts down on frost build-up inside the unit.
- Unit storage bin should not be lined with aluminum foil, wax paper, or paper toweling.
- Liners interfere with cold air circulation, making the unit less efficient.
- Organize and label contents to reduce door openings and extended searches. Remove as many items as needed at one time, and close the door as soon as possible.

TROUBLESHOOTING GUIDE

You can solve many common appliance problems easily, saving you the cost of a possible service call. Try the suggestions below to see if you can solve the problem before calling the servicer.

Problem	Possible cause
Appliance does not operate.	<ul style="list-style-type: none"> Not plugged in. The appliance is turned off. Tripped circuit breaker or blown fuse.
Appliance is not cold enough.	<ul style="list-style-type: none"> Check the temperature control setting. External environment may require a higher setting. The door is opened too often. The door is not closed completely. The door gasket does not seal properly.
Turns on and off frequently.	<ul style="list-style-type: none"> The room temperature is higher than normal. A large amount of contents has been added to the appliance. The door is opened too often. The door is not closed completely. The temperature control is not set correctly. The door gasket does not seal properly.
The light does not work.	<ul style="list-style-type: none"> Not plugged in. Tripped circuit breaker or blown fuse. The Light has burned out.
Vibrations.	<ul style="list-style-type: none"> Check to be sure the appliance is level.
The appliance seems to make too much noise.	<ul style="list-style-type: none"> The rattling noise may come from the flow of the refrigerant, which is normal. As each cycle ends, you may hear gurgling sounds caused by the flow of refrigerant in your appliance. Contraction and expansion of the inside walls may cause popping and crackling noises. The appliance is not level.
The door will not close properly.	<ul style="list-style-type: none"> The appliance is not level. The door was reversed and not properly re-installed. The gasket is dirty. The shelves are out of position.



Warranty

The warranty is for original owners only at the original site of delivery and cannot be transferred to new owners. You must retain your sales slip or invoice as proof of purchase and the original purchase date. To qualify for warranty service, notify us at the address or telephone number below within 60 days of discovering the defect, provide the model and serial number, and describe the nature of the defect.

Blaze appliances are warrantied for single-family/residential use only. The warranty does not cover labor or labor-related charges, shipping & handling costs, or diagnostic charges. All repair work must be performed by a qualified professional service person. Work performed by unqualified persons or incorrect installation will void the warranty. Repair, and maintenance work should be performed by an authorized service technician.

Improper maintenance, excessive humidity, chlorine, fertilizers, lawn pesticides, chemicals, and salt can affect the Stainless Steel components. For these reasons, the warranty does NOT cover discoloration, surface rust, or rust unless there is a loss of structural integrity or rust-through of the appliance components. This warranty covers defects in material and workmanship.

Blaze shall not be liable under this or any implied warranty for incidental or consequential damages. Blaze's liability is limited to the purchase price of the appliance only. Some states do not allow limitations on the duration of implied warranties or the exclusion or limitation of incidental or consequential damages. As such, these limitations may not apply to you. This warranty gives you specific legal rights, and you may have other rights, which vary from state to state.

Warranty Service & Replacement Parts: To obtain warranty service or replacement parts, contact your authorized selling dealer or Blaze Grills directly. Be prepared to provide the purchaser's name, model number and serial number of the appliance, date of purchase, and a detailed description of the problem. The owner is responsible for proper installation, normal care and maintenance, providing proof of purchase upon request, and making the appliance accessible for service. In the event of a warranty replacement, all costs associated with removal, replacement, installation, and shipping are the responsibility of the appliance owner.

Limitations of Warranty: Our obligation to repair or replace, at our option, shall be your sole and exclusive remedy under this warranty. We shall not be liable for incidental, consequential, or special damages arising out of or in connection with the use or performance of the products.

BlazeGrills.com

The express warranties herein are exclusive and in lieu of all other express warranties. We disclaim and exclude all other express warranties for the products and all warranties implied by law, including those of merchantability and fitness for a particular purpose.



1-Yr (limited) Full Replacement Our obligation under this warranty is limited to repair or replacement, at our option, of the product during the warranty period. The extent of any liability of the Manufacturer under this warranty is limited to repair or replacement. This warranty does not cover normal wear of parts, damage resulting from any of the following: negligent use or misuse of the product, use contrary to operating instructions, or alteration by anyone other than our factory service center. The warranty period is not extended by such repair or replacement.



5-Yr (limited) Warranty: Component replacement. For five years from the date of your original purchase of the Products, we will provide, free of charge, Products or parts (including LED light bulbs, if applicable) to replace those that failed due to manufacturing defects subject to the exclusions and limitations below. In our sole discretion, we may choose to repair or replace parts before we elect to replace the Products.



2-Yr Warranty: Compressor only. For two years from the date of your original purchase of the Products, we will provide, free of charge, compressor parts to replace those that failed due to manufacturing defects subject to the exclusions and limitations below. We may choose, in our sole discretion, to repair or replace parts before we elect to replace the Products.

ATTENTION International Customers: Please consult your selling dealer or distributor for specifics pertaining to your product warranty and procedure. Product repair as provided under this warranty is your exclusive remedy. Manufacturer shall not be liable for any incidental or consequential damages for breach of any express or implied warranty on its products. Some states do not allow the exclusion or limitation of incidental or consequential damages or limitations on the duration of implied warranties. As such, these limitations may not apply to you. This warranty gives you specific legal rights, and you may have other rights, which vary from state to state.

This warranty is applicable in the United States and Canada only.

Frequently Asked Questions:

Q: Why is my unit not operating?

A: It could be because the unit is not plugged in, the circuit breaker has tripped or there's a blown fuse, or the temperature control is set to the "OFF" position.

Q: Why does the unit turn on and off frequently?

A: This may happen if the room temperature is hotter than normal, a large number of items have been added to the unit, the door is opened too often, the door is not closed completely, the temperature control is not set correctly, the door gasket does not seal properly, or if the clearance from other high-heat appliances is less than 10 inches.

Q: What should I do if the unit is vibrating?

A: Check to ensure that the unit is level.

Q: Why does the unit seem to make too much noise?

A: Some noise, like rattling, may come from the flow of the refrigerant, which is normal. You may also hear gurgling sounds as the refrigerant flows, or popping and crackling noises due to the contraction and expansion of the inside walls. Additionally, the unit may not be level.

Q: Why won't the door close properly?

A: The door may not close properly because the unit is not level, the door was reversed and not properly installed, the gasket is dirty or bent, or the shelves, bins, or baskets are out of position.

Please leave these instructions with the consumer.

Please read and retain these instructions for future reference and before installation or operation.

Contact Us:

Blaze

3401 Oak Villa Blvd. Baton Rouge, LA 70814

Phone: 866-976-9510

customerservice@blazegrills.com

Contact Us:

 **@Blazegrills**

 **@Blaze_Grills**

 **@BlazeOutdoorProducts**

